

Custom LitePad®

Handling & Mounting Guide

Low profile light emitting LED panel for backlighting or area lighting, available in standard or custom sizes and fixed white, tunable white or RGB LED configurations, and dimming and control accessories.

Environmental Consideration

- Unless otherwise specified, this product is intended for indoor use with ambient relative humidity levels of 10% to 90% (non-condensing). LitePads with IP65 rating are available upon request.
- Maintain proper ambient temperatures where power supplies and control devices are located to avoid thermal overload and sudden loss of power to LitePad. Check component specifications for maximum recommended ambient conditions.
- Maintain ambient temperature of 40°C maximum for optimum LitePad performance.

Handling & Mounting Tips

- Do not bend or twist LitePad. Bending can damage the LEDs.
- Do not cut or modify LitePad as this can result in damage to the LEDs or heat sink and void the product warranty.
- Do not remove the heat sink (aluminum strips on back surface) from the LitePad.
- LitePads must be supported every 18" (46cm) in each direction for horizontal installations; every 36" (92cm) for vertical installations.
- Do not use adhesive to attach LitePad to any surface for mounting. The LitePad construction does not support this type of mounting arrangement.
- We recommend a space of approximately 1/8" (3mm) between the LitePad and non-conductive substrates to allow for air movement and optimum heat dissipation.
- LitePads are fabricated from PMMA Acrylic with coefficient of thermal expansion = 70×10^{-6} in/in/°K – this expansion should be taken into consideration when evaluating ambient conditions and mounting methods for the project installation.
- Common mounting methods include, but are not limited to the following. Mounting method is the responsibility of the installer, but should be communicated to the Rosco Project Coordinators to ensure compatibility with LitePad design.

- Mirror Brackets or Z-Clips

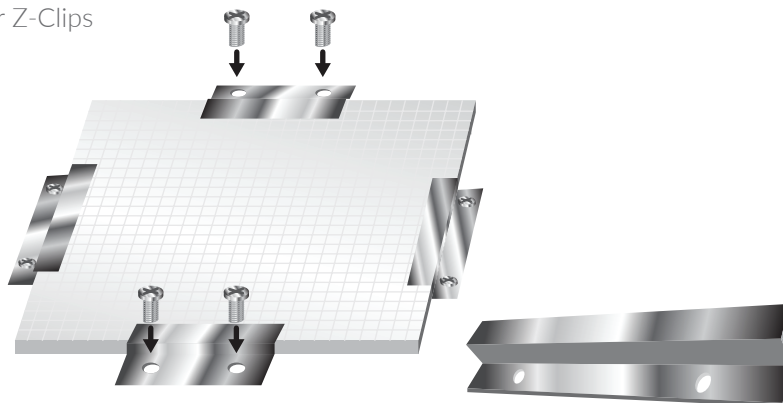

Handling & Mounting Guide

- Architectural Stand-Offs

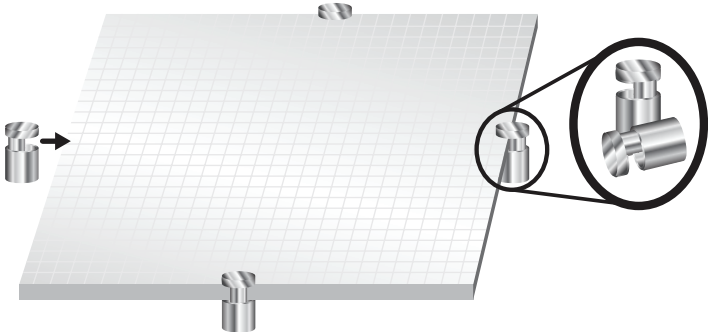

- Architectural channel or custom millwork

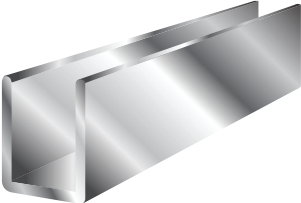

- Pre-drilled holes in panel body (this option should be specified during panel construction to avoid on-site drilling and possible damage to panels). Always utilize minimum 1/8" (3mm) spacer between LitePad and substrate when mounting with screws/bolts to ensure proper heat sink performance.

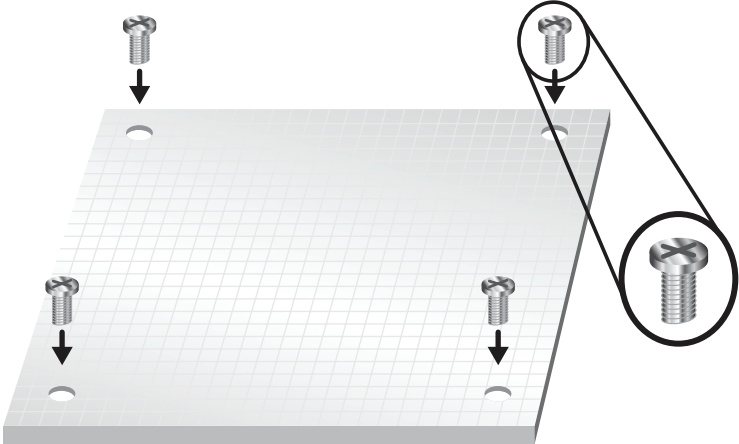

Handling & Mounting Guide

- Location of the lead wire exit point should be confirmed during the design phase to ensure proper strain relief and integrity of the installed LitePad. Options include corner exit, side exit, notched corner and rear panel exit.

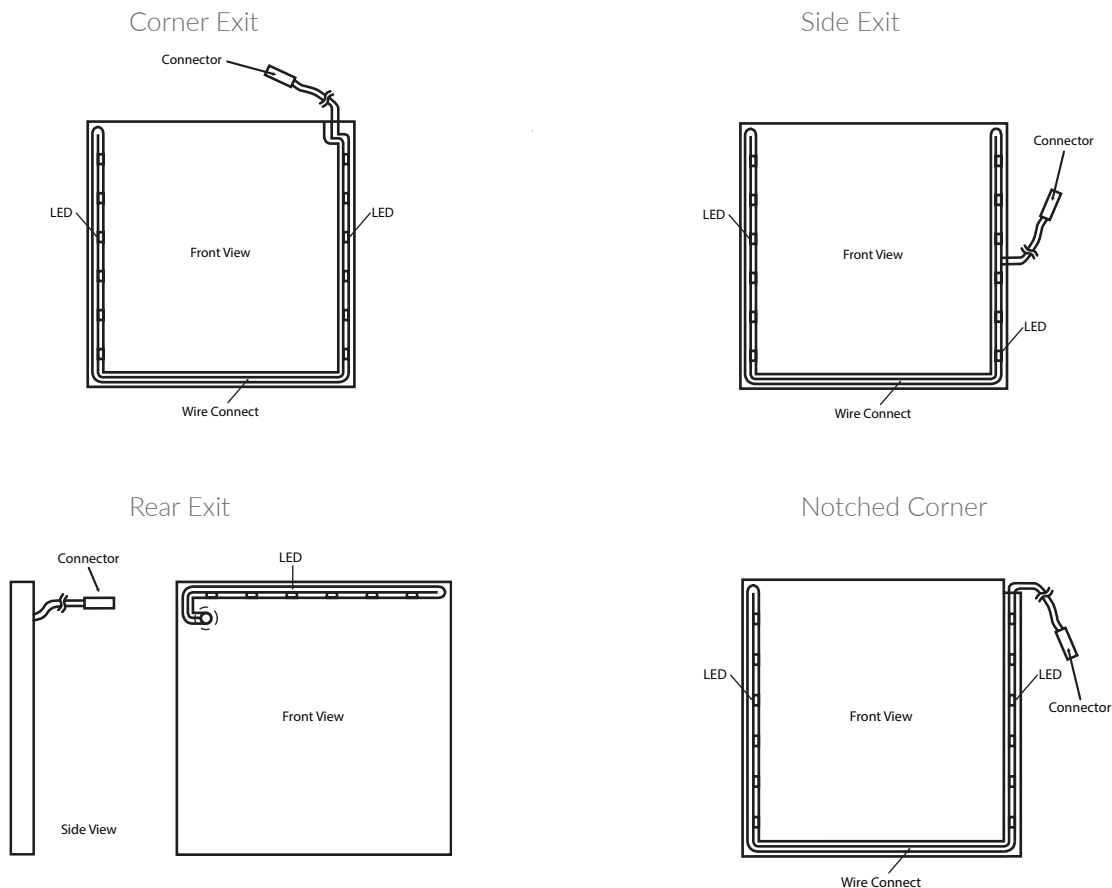

- Notched corner exits allow LitePad panels to be placed adjacent to one another.
- Rear panel exits include strain relief and requires clearance in the mating surface for flush mounting
- LitePad lead wire minimum bend radius = 0.375 in. (9.5 mm).

Light Quality Considerations

- Do not use alcohol or solvents to clean LitePad as these can cause clouding of the surface. Use a soft microfiber cloth dampened with mild soap & water solution.
- Do not glue graphics or laminates directly onto the acrylic surface as adhesive may alter light uniformity and/or diffusion properties and may damage the acrylic.
- Always remove clear plastic protective layer from front surface prior to installation. Failure to remove plastic will result in non-uniform appearance.

Wiring Basics

- LitePad requires 12VDC power supply. Never apply AC power to the LitePad as this will damage the LED's and void product warranty.
- LitePad HO90 is supplied with 20 AWG lead wires, 4-ft (1.2m) length with integrated 5.5mm x 2.1mm barrel connector, which can be connected to an available desktop power supply, or can be removed for terminal connection onto a number of available power and dimming controls.
- LitePad RGB and CCT are supplied with 22 AWG lead wires, 4-ft (1.2m) length with unterminated ends.
- The distance between the LitePad and power supply should be kept as short as possible to avoid voltage drop. Use heavier gauge wire for longer distances. See below table for examples of typical voltage drop for 5A load with 12VDC power supply. Check with your electrical designer to confirm the correct wire size for your installation.

Power Supply to LitePad Distance	Min. Wire Gauge (AWG)	Min. Wire Diameter (Metric)	Voltage @ End of Run	% Voltage Drop
5-ft (1.52m)	20	0.81mm	11.49	4.25
10-ft (3.05m)	18	1.02mm	11.36	5.33
20-ft (6.1m)	16	1.47mm	11.20	6.67
30-ft (9.14m)	14	1.85mm	11.24	6.33
40-ft (12.2m)	12	2.35mm	11.36	5.33

- Ensure appropriate strain relief to the lead wires so as to avoid stress on the connection to the LitePad. LitePad lead wire minimum bend radius = 0.375 in. (9.5 mm).
- Use only Rosco approved 12VDC approved power supplies and dimming controls. All other components may damage LEDs and void warranty.
- Always ensure the total LitePad wattage does not exceed those of the power supply and dimming controls.
- Always connect multiple LitePads in parallel to a common power supply, never in series.
- All LitePads use a common (+) lead wire. See below for various wiring color codes:

	IP43 Product Sold in N. America	IP65 Product Sold in N. America	All Products Sold in Europe
HO90:			
(+) Lead	Black w/White Strip	Black w/White Strip	Black w/White Strip
(-) Lead	Black (no stripe)	Black (no stripe)	Black (no stripe)
CCT:			
Common (+) Lead	White	Black	Black
Warm White (-) LED Lead	Gray	Red	Red
Cool White (-) LED Lead	Black	Green	Green
RGB:			
Common (+) Lead	Yellow	Black	Black
Red (-) LED Lead	Red	Red	Red
Green (-) LED Lead	Green	Green	Green
Blue (-) LED Lead	Blue	Blue	Blue

These handling and mounting materials and any other communications related to installation of the Custom LitePads are offered for informational purposes only. Handling and mounting of Custom LitePads is the installer's responsibility. Under no circumstances is Rosco assuming any liability, express or implied, regarding the installation or application of any of its Custom LitePads, whether proper or improper. Further, Rosco assumes no liability for any costs associated with the installation or re-installation of any of its Custom LitePads.

Custom LitePad[®] Cleaning Guide

LitePad can become scratched on the surface from harsh cleaners or abrasive scrubbers. These cleaners produce small scratches on the surface of the acrylic, resulting in a cloudy look. Once the damage has been done, it is difficult to undo it. Here are the proper cleaning techniques for LitePads

You Will Need:

- Water
- Non-abrasive, lint-free cloth
- Mild, non-abrasive cleaner (liquid dish soap)

Steps to Clean Rosco Custom LitePad:

- Determine how strong of a cleaning solution is needed by observing the amount of dirt present.
- If there is only a small amount of dust, then water is sufficient. If there is more significant dirt build up, then you may wish to mix in a mild, non-abrasive detergent with water.
- If the surface has just a small amount of dirt, use a soft cloth moistened with water to gently wipe it away. Turn the cloth often to keep a clean side on the surface. It is important to avoid rubbing the dirt on the surface because it can cause more scratching.
- For more significant amounts of dirt, use a cloth that is very wet with water. Gently swab the cloth on the surface and allow the water to lift the dirt, again turning the cloth often to keep a clean side on the surface. Use multiple cloths if necessary.
- To remove more obstinate stains, especially grease or rubber scuffs, use Isopropanol (not Isopropyl).

Additional Tips:

- Avoid any cleaning products with ammonia as it will eat through the surface and leave it looking cloudy.
- Other cleaners that should be avoided include ketones, halogens, window cleaners, anything with a scouring compound, solvents such as thinners and acetone. Any cleaner that is abrasive or strong enough to eat through the surface should be avoided.

If you have any questions about cleaning Rosco LitePads, please contact Rosco directly.